

# QS-525 /QX-1900

15" All-in-one POS Terminal



# Features

---

1. Multiple technological platforms (M22, M62 motherboards)
2. True-Flat Projected Capacitive Technology
3. Fanless design (M22, M62)
4. IP65 (Front only)
5. Rich I/O and rich peripheral options
6. Die-casting rear housing for optimum thermal dissipation
7. Die-casting stand for optimum stability
8. Cable cover to help preventing unwanted tempering
9. Wide tilt angle customer display for easy and comfortable viewing
10. Easy HDD access
11. Discreet yet easy to access power button
12. Standard 100x100 VESA holes for pole-, wall-, and stand- mountings

# Features - Optional

---

## 1. Rich peripherals:

- MSR,
- MSR + FP reader Combo,
- MSR + iButton Combo,
- MSR + RFID Combo,
- 9.7" Second Display,
- VFD 2x20 Customer Display

## 2. Dual stereo speakers (Optional)

# Features – Rich Peripheral Options

---

- 2nd Display : 9.7" (1024 x 768)



- Customer Display



# Features – Rich Peripheral Options

---

- MSR



- Combo



MSR + Finger Print



MSR + iButton



MSR + RFID

# Features – Rich I/O

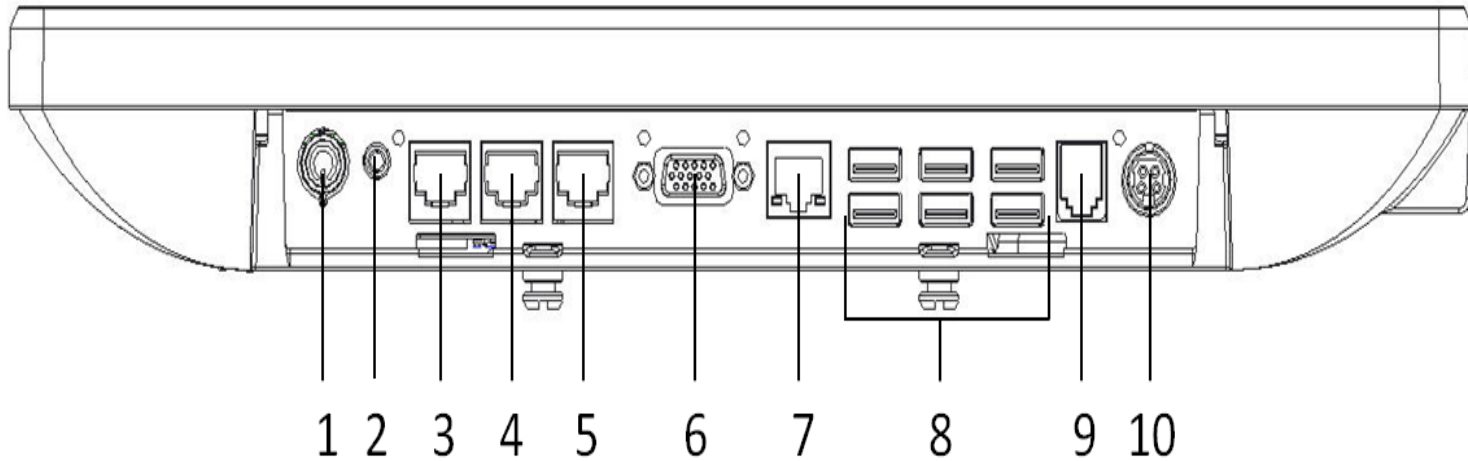

Item No.	Description
1	Power Button
2	Spkr-Out & Mic-In Combo Jack
3	COM1 (RJ45)
4	COM2 (RJ45)
5	COM3 (RJ45)
6	VGA
7	LAN
8	USB 2.0 x 6
9	Cash Drawer
10	DC-In (12V)

# Features – Easy Cable Installation

---

Easy cable installation



# Features – Easy access to HDD & Power button



Discreet yet easy to  
access Power Button



# Feature - IP65 & Cable Cover

---



**IP 65 (Front side)**



**Cable Cover helps to prevent unauthorized tampering**

# Features – Mounting Options

---

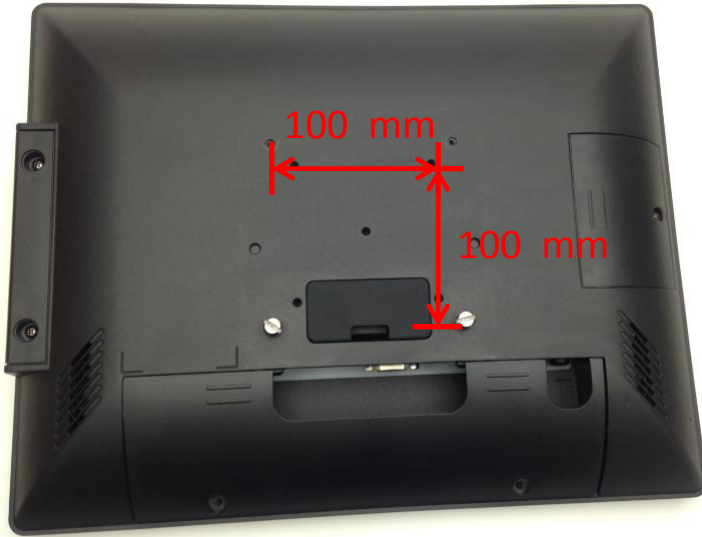

Standard VESA



Stand-Mount



Pole-Mount



Wall-Mount

# Dimensions

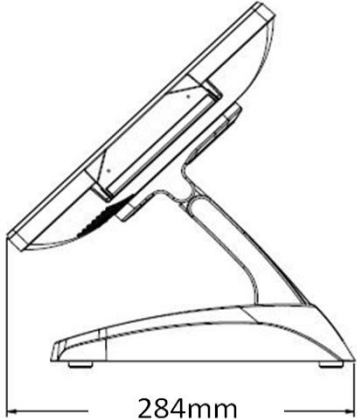
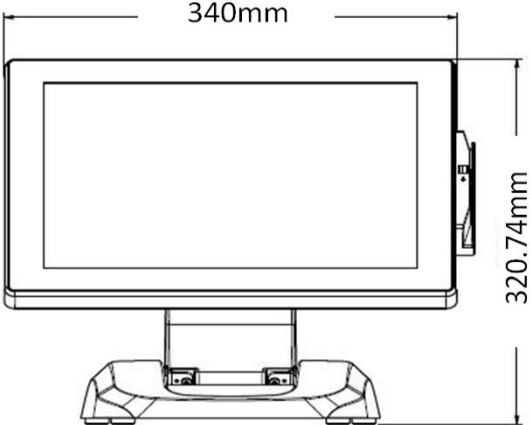

**System Upright**

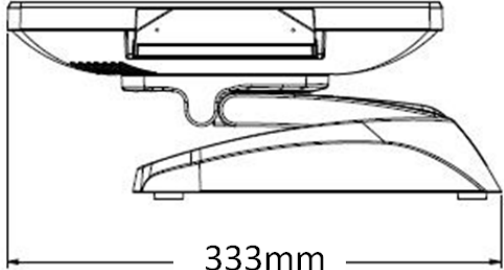
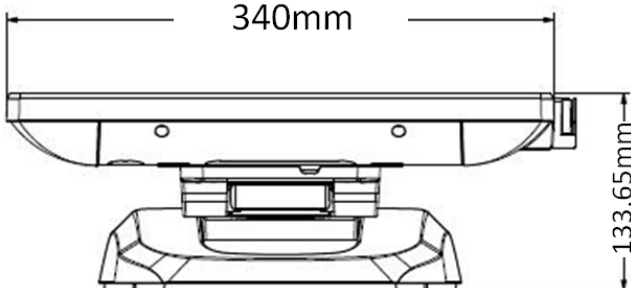

**System Folded**

# Spec

model		QS-525	QX-1900
Main Board		M22 (PineView)	M62(Bay Trail)
CPU Support		Intel Pineview D525 processors 1.8GHz	Intel Bay Trail- D J1900 2G, L2 2M
System Memory		DDR3, SO-DIMM x 1, 2GB (Max. 4GB)	DDR3L, SO-DIMM x 2, 2GB (Max. 8GB)
Storage	HDD	320GB 2.5" x 1	
	SSD	SSD x 1 (Optional)	
LCD	Size	15" TFT LED LCD Panel	
	Brightness	350cd/m2 (Typ.)	
	Resolution	1024 x 768	
Touch Screen		True-Flat Projected Capacitive Touch	
Tilt Angle		0 ~ 120 degree	
External I/O Port		6 x USB 2.0 Ports	
Rear	3 x Serial port (RJ45); (COM1~2: 0/5/12V by BIOS; COM3:0/5V by BIOS)		3 x Serial port (RJ45); (COM1~3: 0/5/12V by BIOS)
	1 x VGA (Power enable by BIOS; +12V)		
	1 x Cash Drawer Port (RJ11; +12V)		
	1 x LAN (10/100/1000)		
	1 x Mic-In/Speaker-out (Combo Jack)		
	1 x DC In		
	1 x Power Switch		
	2 x 2W speaker (Optional)		
Speaker		External power adapter, 60W/12V (Lock type)	
Power		CE, FCC Class A	
EMC Safety		0°C ~ 35°C	
Environment	Operating Temperature	-20°C ~ 60°C	
	Storage Temperature	20% - 85% RH non condensing	
	Operating Humidity	20% - 85% RH non condensing	
	Storage Humidity		
OS Support		Windows® 7 Professional, Windows® Embedded POSReady 7, Linux, Windows 8.1 ( only for QX-1900)	
Wall Mount		VESA 100 x 100mm	
MSR (USB)	MSR		MSR + Finger Print (Combo)
			MSR + iButton (Combo)
			MSR + RFID (Combo)
Customer display (USB)		Flush mount VFD display, 2x20 characters	
2nd Display		10" (1024 x 768)	